

# ANDREW YULE & COMPANY LIMITED

## TEA DIVISION

### NEW DOOARS TEA ESTATE

#### TENDER FORM FOR CONSTRUCTION OF SINGLE UNIT LABOUR LATRINE

#### PART - A

##### **Scope of Job :**

The job consists of construction of 40 nos. Single Unit Labour Latrine in the four Dooars gardens viz. Banarhat (6 units), Karballa (14 units), New Dooars (10 units) and Choonabhutti (10 units) Tea Estates. The entire job will be given on turn-key basis & the Contractor should complete the entire operation within the stipulated time frame & hand over the Latrines to the garden. **Tenderers should visit the gardens & physically check the areas where the Latrines are to be constructed.**

Quotation need to be submitted in two parts. In **PART-A** commercial conditions & credentials need to be submitted. Those who fulfill the criteria mentioned in "Part A" shall only be eligible to participate in the financial bid which is detailed in PART-B.

Drawings are part of the tender and are given in Annexure I of Part A. Specification of Materials which can be used is given in Annexure II of Part A. Tenderers are advised to complete both the parts & put **PART-A & PART-B** in two separate sealed envelopes superscribed with the words "**Tender for Single Unit Labour Latrine PART-A**" & "**Tender for Single Unit Labour Latrine PART-B**". The two separate envelopes should then be put in one single envelope sealed & superscribed with the words "**Tender for Single Unit Labour Latrine PART-A & PART-B**". **The job may be split between more than one party & management's decision in this regard shall be final & binding.** Any of the applications received may be rejected without assigning any reasons whatsoever. **Please attach Demand Draft of Rs.10,000/- (Rupees Ten Thousand only) as Earnest Money Deposit in favour of "Andrew Yule & Co. Ltd., New Dooars Tea Estate" payable at Banarhat/Siliguri.**

The application needs to be addressed to :

The Manager  
New Dooars Tea Estate  
P.O.: Banarhat,  
Dist.: Jalpaiguri, W.B.,  
Pin.: 735202.

Contd.....Pg/2

The following conditions needs to be fulfilled before the applicant is eligible to quote.

**( To be filled in by the applicant )**

1. Full Name of the firm : .....
2. Full Postal address of the Firm .....  
With telephone number, .....  
(Office & mobile), E-mail id .....  
.....
3. A. Whether Registered under MSME (SSI) : Yes/No .....  
(If Yes, please submit a photocopy)  
B. Whether Owned by SC/ST entrepreneur : .....
4. PAN Card Number with photocopy : .....
5. GST number with photocopy : .....
6. Trade Licence Number with photocopy : .....
7. Bank Account Number, :.....  
Name of the Bank with Brach & address .....  
.....  
.....
8. Bank certificate regarding  
Normal operation of your Account : .....
9. The firm should have past experience Of Construction .....  
of Single Unit Labour Latrine for last 3 years in Tea Industry in  
Jalpaiguri/Siliguri area.  
( Photocopy of past orders need to be submitted )
10. E. M. D : **Rs.10,000.00** Draft No.:.....  
Date :.....  
  
( Which shall be returned after successful completion of the job but shall  
be forfeited if the project is abandoned midway except for any act of god/  
riots/ any Govt. regulation/ Political Disturbance/ Disturbance due to Wild  
animals )

**Tender Form : Rs.500/-, To be paid in Cash/DD while collecting from the garden.  
In case of downloads from web-site, it should be paid through Demand Draft to be  
attached with this form.**

All Bankers Cheque/ Demand Drafts to be drawn in favour of **“Andrew Yule &  
Co. Ltd., New Dooars Tea Estate ”payable at** Banarhat/Siliguri.

Contd.....Pg/3

1. Work is to be completed within **120 days** from the date of the order.
2. All rates quoted will remain fixed until the job is completed & NO Price revision will be allowed, for any reason, whatsoever.
3. Penalty clause shall be applicable if the job is not completed within the stipulated time in Purchase Order. Penalty will be 0.5% of Project Value for each week of delay from the scheduled date of completion, maximum of 5% of total project value.
4. Any delay or failure in the performance of either party hereto will not constitute default thereunder or give rise to any claim for damages, if any, to the extent such delays or failure of performance is caused by the concurrence such as acts of god, or the public enemy, appropriation or confiscation of facilities by Govt. Authorities, acts of war, rebellion or sabotage, fires, explosions, riots and illegal strike.
5. All the applicable labour laws relating to deployment of labourers/employees will be strictly followed in executing the contract.
6. No advance will be given. Part payment will be released on the basis of submission of actual bills subject to 10% retention at each stage which will be released after six months of successful completion of the project, if no dispute arises regarding quality of the project.
7. Bidding for each item is a must. Quotation submitted in incomplete form will be rejected.
8. Replacement of the defective/substandard material/job has to be made good within 15 days.
9. Management reserves the right of inspection at any time.
10. Management reserves the right to reject any or all quotations, without assigning any reason whatsoever.
11. The Quotations must include packing and delivery charges at the Garden and no collection of stores will be made from your go down unless specifically agreed to.
12. Please quote for only those Make and Brand as stated in the LIQ.
13. All alterations in the quotations must be attested by full signature.
14. Rates are to be inclusive of all applicable Taxes/GST unless otherwise specifically stated in your quotation.
15. Actual need based Order quantity may vary from the indicated quantity at the sole discretion of Garden Management.
16. The specifications can not be changed. A tender who is unable to supply the materials or work as per specification, may however give Quotations for alternative items but this must be done on a separate sheet of paper or letter head of the Firm with the words "See item ..... in the enclosed sheet" in this form.
17. In the event of failure to make supply or correct supply within the stipulated period the Garden will be a liberty to make the purchase elsewhere and the tenderer shall be liable to make good any loss suffered by the garden as a result of such purchases.
18. Taxes will be deducted as per statute.
19. All Disputes are subject to Jalpaiguri jurisdiction only.
20. Quotation will be valid for 6 months from the date of opening.

**Last date of submission of Tender : 2<sup>nd</sup> November, 2017.**

**Date & time of opening of the Tender : 3<sup>rd</sup> November, 2017, at 11 am.**

I have read the tender papers & have understood the detailed process.

I agree to all the terms & conditions mentioned above.

Date :

\_\_\_\_\_  
Signature of the Party with Office Seal

Contd. ... Pg/4

**Annexure - I**

YULE/Lavatory/01

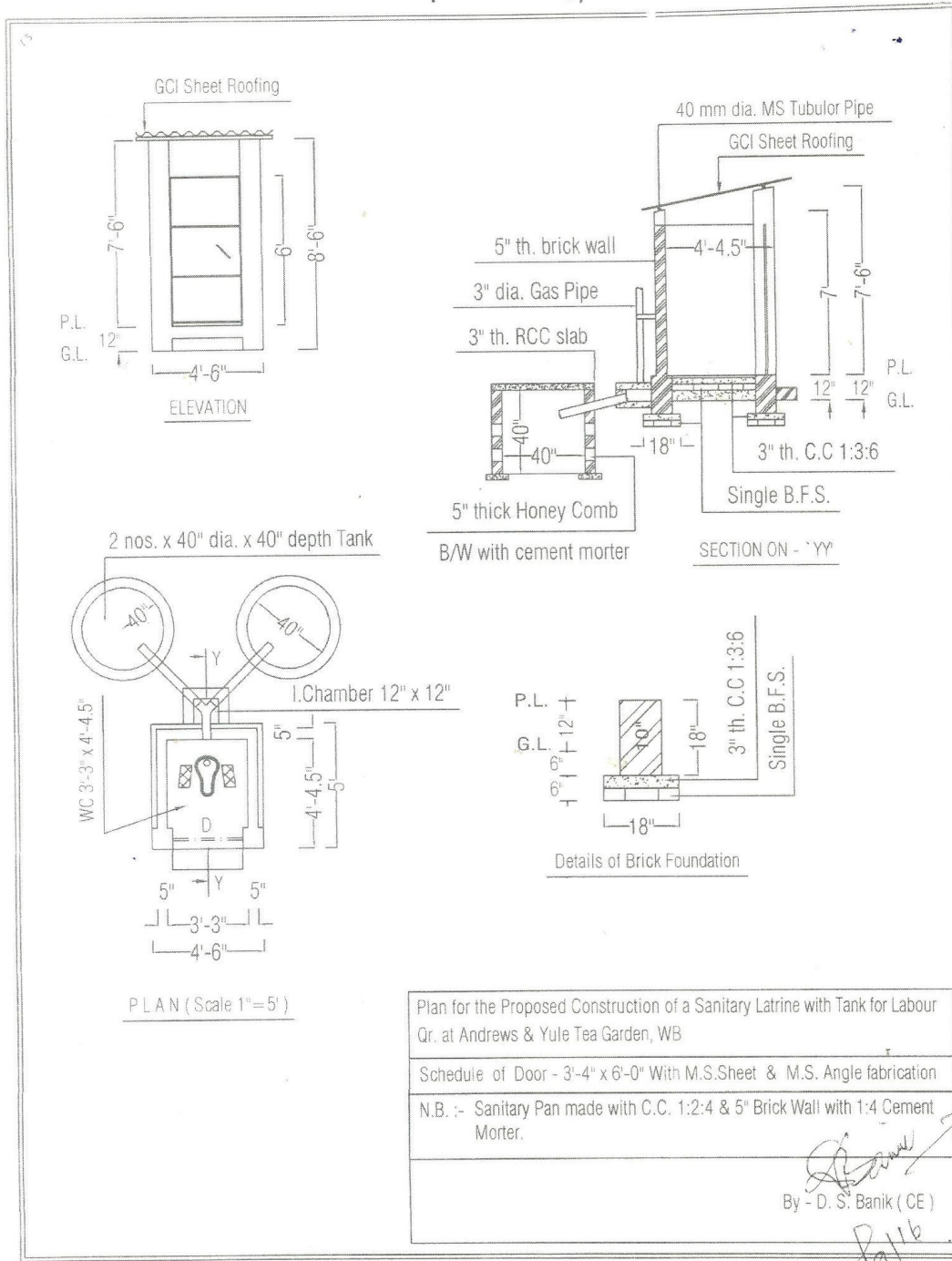

Plan for the Proposed Construction of a Sanitary Latrine with Tank for Labour Gr. at Andrews & Yule Tea Garden, WB

Schedule of Door - 3'-4" x 6'-0" With M.S. Sheet & M.S. Angle fabrication

N.B. :- Sanitary Pan made with C.C. 1:2:4 & 5" Brick Wall with 1:4 Cement Mortar.

By - D. S. Banik (CE)

Place :

Date :

Signature of the Applicant with Office Seal

Contd.....Pg/5

**Annexure – II****Specification of the materials to be used in the project.**

1)	Cement (53 Grade) to be used as per IS Code 12269 of the following brand	a) Ambuja b) Lafarge c) ACC d) Ultratech
2)	Traditional Bricks (1 <sup>st</sup> Class) to be used as per IS Code 3495 of the following brand	a) Super b) Arun c) Apolo
3)	Sand (Coarse, Medium, Fine) to be used as per ISA Code 383 of the following river bed	a) Rangati reiver bed
4)	Stone Chips (Crushers) to be used as per IS Code 2386 Part II of the following product	a) By Crusher Machine
5)	Shingles (River beded) of proper sizes to be used as per IS Code 2386 Part II of the following River bed.	a) By Chamurchi River bed
6)	R.B.M. (River beded materials) 2:1:1 to be used of the following River bed	a) By Chamurchi River bed
7)	M. S. Rod / Torq Rod to be used as per IS Code 2751 of the following branded	a) Tata b) Elegant
8)	GCI Sheet for roof to be used as per IS Code 277 of the following branded	a) Tata 0.60 mm
9)	AC Sheet for roof & ridging to be used as per IS Code 459 of the following branded	a) Rhino b) Charminar
10)	AC plain sheet for ceiling to be used as per IS Code 2096 of the following branded	a) Rhino b) Charminar
11)	Lime for white wash to be used as per IS Code 712 of the following branded	a) Maa Kali b) Apple
12)	Red oxide primer to be used as per IS Code 102 of the following branded	a) Berger b) Shalimar
13)	Primer / Enamel paint to be used as per IS Code 2932 of the following branded	a) Berger b) Shalimar
14)	Shuttering wood to be used as per IS Code 4990	a) With 25mm thick H.W.

Place :

(Signature of the Applicant)  
With Office Seal.

Date :

**PART - B**

PAGE 1

**Schedule of Works for Construction of Toilet with tank (one Set)**

Item No	PARTICULARS OF WORK	QTY .	UNIT	RATE	AMOUNT
1 )	Earth Work in excavation of foundation trenches or drains in all sorts of soil (including mixed soil but excluding latrite soil or sandstone ) including removing, spreading or stacking the spoils with in a lead of 75 m as directed. The item includes necessary trimming the sides of trenches, levelling, dressing, and ramming the bottom, bailing out water as required complete .  ( a ) Depth of excavation not exceeding 1.50 M  As per IS Code - 1200 Pt. I-1992	3.50	Cu.M.		
2 )	Earth work in filling in foundation and trenches or plinth etc. in layers not exceeding 150 mm including watering and ramming etc. complete .  ( a ) With earth obtained from excavation of foundation .	0.70	Cu.M.		
	( b ) with earth obtained by fresh excavation (including cost of excavation upto 1.80 m depth from land arranged by Deptt. ) Within a lead of 100 m.  For plinth filling -	2.80	Cu.M.		
3 )	Single B.F.S. of picked jhamma bricks including ramming and dressing bed to proper level and filling joints with powdered earth or local sand .  As per IS Code - 1077-1992	3.60	Sq.M.		
4 )	Cement Concrete ( 1: 3: 6 ) with 40 mm down graded shingles excluding shuttering.  As per IS Code - 456-2000	0.408	Cu. M.		
5 )	Ordinary Cement Concrete M 15 ( mix 4: 2: 1 ) with 20 mm down graded stone chips / shingles excluding shuttering and reinforcement if any, in ground floor .  ( a ) Crushers -  As per IS Code - 456-2000	0.185	Cu. M.		

6 )	<p>Reinforcement for reinforced concrete work in the all sorts of structures including distribution bars, stirrups, binders etc. including supply of rods, initial streaghtening and removal of loose rust ( if necessary ), cutting to requisite length, hooking and bending to correct shape, placeing in proper position and binding with 16 gauge black annealed wire at every intersection, complete as per drawing and direction .</p> <p>( a ) For works in foundation, basement and upto roof of ground floor / upto 4.0 m .</p> <p>( i ) Tor Steel / Mild steel .</p> <p>@ 0.80 % of ( C.C. work for M15 ) 0.185 Cu.M =</p> <p>As per IS Code - 432-1982</p>	0.12	Quintel		
7 )	<p>Brick work with 1 st class bricks in cement mortar ( 6 : 1 ) .</p> <p>( a ) In foundation &amp; plinth</p> <p>( b ) In superstructure, ground floor</p> <p>As per IS Code - 2212-1991</p>	0.563	Cu. M.		
8 )	<p>125 mm thick brick work with 1st class bricks in cement mortar ( 4 : 1 ) in ground floor .</p> <p>As per IS Code - 2250-1981</p>	15.20	Sq.M.		
9 )	<p>Artificial stone in floor, dado, staircase etc. with cement concrete (4:2:1) with stone chips laid in panel as directed with topping made with ordinary or white cement ( if necessary ) and marble dust in propertion ( 2:1 ) including smooth finishingand rounding off corners and including application of cement slurry before flooring works using cement @ 1.75 Kg / Sq.M all complete including all materials and labour .</p> <p>3 mm thick topping with ordinary cement ( High polishing grinding on this item is not permitted ) .</p> <p>( a ) 20 mm thick -</p> <p>As per IS Code - 2571-1970</p>	1.35	Sq.M.		
10 )	<p>Supplying, fitting and fixing steel doors with or without integrated grills conforming to I.S. 7452 - 1973 with non friction projecting type hinges, glazing chips, lugs, locking plate, peg stays, 1.25 mm thick M.S. sheet welded kicking</p>				

	plates in double tray construction brass door handle with minimum 4 lever mortice lock openable with key both from inside and outside together with a locking bolt on the inside face including hoisting in position, straightening, if required fixing lugs in cement concrete ( 1:2:4 ) with stone chips 20 mm size cutting holes and mending good damages to match with existing surface complete in all respect including glazing . ( b ) Openable steel Door / windows - As per IS Code - 1038-1983	1.800	Sq.M.		
11 )	M.S. structural works in roof trusses with Tubular sections conforming to IS: 806 - 1957 & IS :1161-1958 connected to one another with bracket, gusset, cleats as per design, direction of Engineer In Charge complete including cutting to requisite size, fabrication with necessary metal are welding conforming to IS : 816 - 1956 & IS : 9595 using electrodes of approved make and brand conforming to IS : 814 - 1957, haulage, hoisting, and erection all complete . The rate includes the cost of rolled steel section, consumables such as electrodes, gas and hire charges of all tools and plants and labour required for the work including all incidental charges such as electricity charges, labour insurance charges etc ( a ) For trusses spanning upto 12.0 M	0.080	Quintel		
12 )	Galvanized corrugated iron sheet work ( excluding the supporting frame work ) fitted and fixed with 10 mm dia. J or L hook bolts, limpet and bitumen washers and putty complete with 150 mm end lap & one corrugation minimum side lap complete. ( i ) In roof ( b ) With 0.60 mm thick sheet As per IS Code - 277-2003	4.680	Sq.M		
13 )	Plaster ( to wall, floor, ceiling etc. ) with sand and cement mortar including rounding off or chamfering corners as directed and racking out joints or roughening of concrete surface including throating, nosing and drip course where necessary in G. floor . ( i ) With ( 6 : 1 ) cement mortar ( b ) 20 mm thick plaster ( c ) 15 mm thick plaster As per IS Code - 2250-1981	12.00 15.00	Sq. M Sq. M		
14 )	Neat cement punning about 1.50 mm thick in wall, Dado, window sills, floor, drain etc. Cement to be used 0.152 Cu.M per 100 Sq.M	2.00	Sq. M		



Page 4					
15)	Red oxide wash of approved shade including cleaning and smoothening surface thoroughly ( without specific permission from the Engineer in charge this item of work must not be done on an old painted surface which has not received such red oxide wash before ) .  ( b ) One coat -  As per IS Code - 102-1962	4.00	Sq.M.		
16)	Painting with best quality synthetic enamel paint of approved make and brand including smoothening surface by sand papering etc. including using of approved putty etc. on the surface if necessary  ( b ) On steel or metal surface ( iv ) Two coats ( with any shade except white )  As per IS Code - 13607 - 1992	4.00	Sq.M.		
17)	White washing including cleaning and smoothening surface thoroughly ( 5 parts of stone lime and 1 part of shell lime should be used in the finishing coat ) .  ( b ) Two coats -  As per IS Code - 6278-1971	25.00	Sq.M.		
18)	Sanitary works for fitting Pan, Trap, pipe, gas pipe etc as complete	L. S.	L. S.		
		<b>GRAND TOTAL</b>			

\_\_\_\_\_  
Signature of the Applicant  
With Office Seal.

Place :

Date :